

# ALL the POWER without the HEAT!

## Induction: A New Way To Cook

For thousands of years, man has continued to develop more sophisticated tools to cook food. Induction is not only the latest in this long line of inventions, it is also the most revolutionary.

Induction offers unprecedented performance: quick heating and precise, accurate control mean energy savings and impeccable results. Increased safety too: there is no flame, no heat source—only the food and pan get hot. Easier, more economical and safer to use, induction is the natural choice for today's professional cooks.

## Induction by Diva

Introducing Induction by Diva. It began with extensive research in the lab, but soon we stepped out into the top kitchens to work beside the best chefs of France, Europe and North America. We studied and cooked with them and asked them what they wanted if they could have the ideal induction cooktop.

The result is the Diva Induction Cooktop, a revolutionary instrument in function and design. Diva Induction Cooktops are designed for foodservice professionals who demand power. Incorporating the latest European technology with the highest grades of stainless steel and vitroceramic glass, Diva Induction Cooktops deliver power fast and can be adjusted to the perfect setting even faster.

## Technology for the 21<sup>st</sup> Century

Diva Induction Cooktops are powered by a 3600 W coil that delivers power and flexibility at the touch of a button. Using the latest capacitive controls, each cooktop offers digital touch displays with 4 presets and 12 power levels. All controls are enclosed inside the unit and covered by glass to minimize incorrect readings and breakage.

The 11" double generator coil automatically detects pan diameter and adjusts to ensure maximum coverage. It is equipped with built-in safety features including empty pan detection and boil over.



**Induction by Diva, the art of technology.**



**FINALLY, AN INDUCTION COOKTOP THAT'S  
AS CONSCIOUS OF PRICE AS IT IS POWER.**

## Cooktop Specifications:

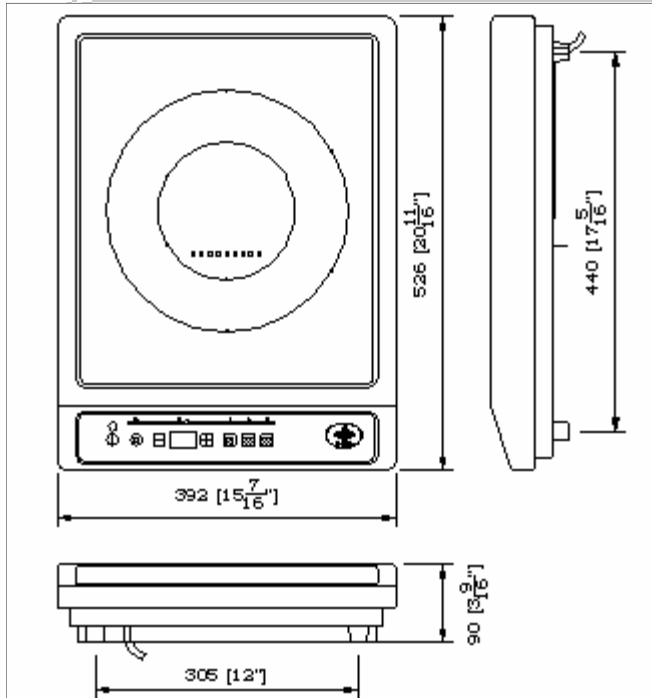

### Div10CT

Usable Cooking Surface: 13.5" X 16"  
 Power: 208-240V, 1Ph, 60Hz  
 Weight: 9.4kg / 21lbs

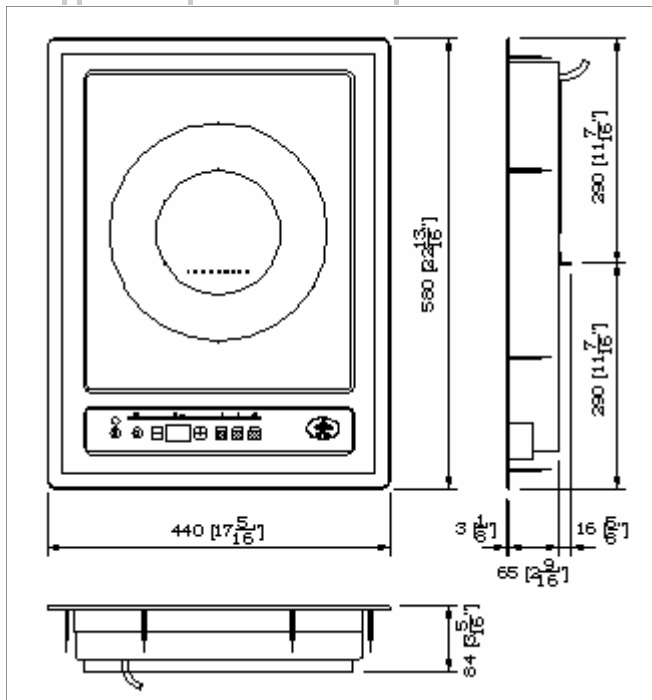

### Div10DI

Usable Cooking Surface: 13.5" X 16"  
 Power: 208-240V, 1Ph, 60Hz  
 Weight: 11kg / 24lbs



Div10 Induction Cooktops are available as single burner units, designed for either freestanding or drop-in applications.  
 All Div10 Induction Cooktops are approved for use in North America.

**Div10 de Provence**  
 885 Don Mills Road, Suite 207, Toronto, ON Canada M3C 1V9  
 Toll-Free: 888.852.8604 / [www.divainduction.com](http://www.divainduction.com)
